

### Technical data

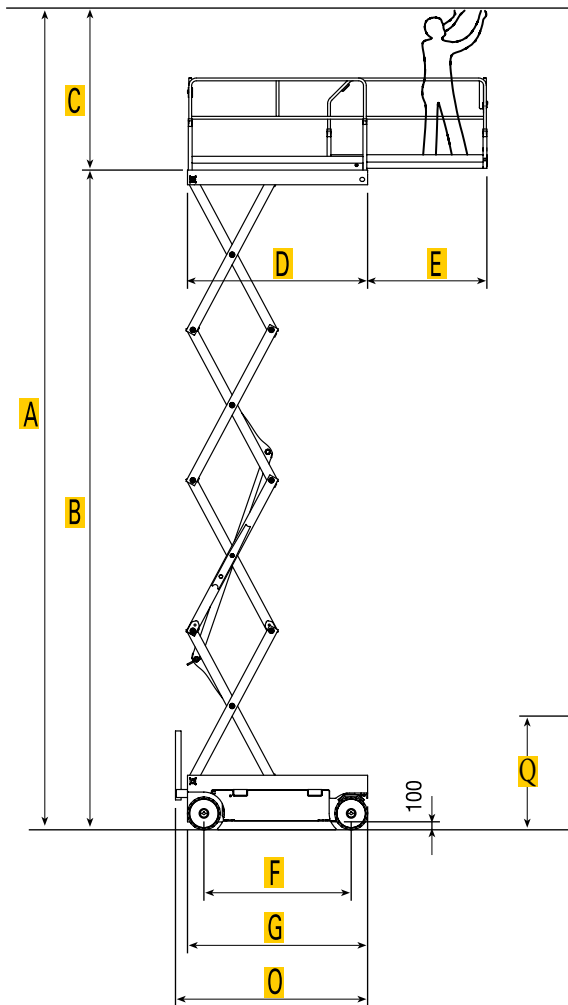

	X8	X10	X12	X14
A	8300	10200	12100	14000
B	6300	8200	10100	12000
C	2000	2000	2000	2000
D	2250	2250	2250	2250
E	1500	1500	1500	1500
F	1840	1840	1840	1840
G	2250	2250	2250	2250
H	890	890	890	890
I	1150	1150	1150	1150
L	1080	1270	1390	1520
M	2230	2420	2540	2670
N	890	890	890	890
O	2400	2400	2400	2400
P	1730	1920	2040	2170
Q	1280	1480	1600	1720

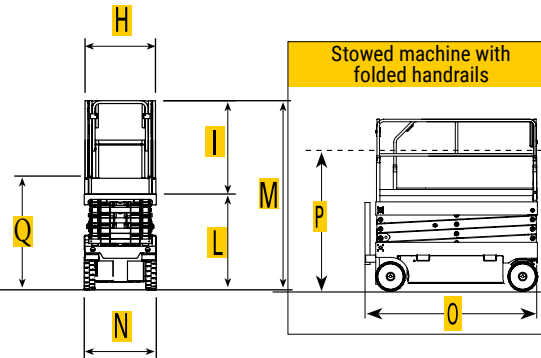

TECHNICAL SPECIFICATIONS		X8 EN	X10 EN	X12 EN	X14 EN
Max. working height	mm	8300	10200	12100	14000
Max. platform height	mm	6300	8200	10100	12000
Total capacity / n° of persons	kg	400/3	400/3	300/3	230/2
Capacity on deck extension	kg	400	400	300	230
Manual roll-out extension deck	m	1,5	1,5	1,5	1,5
Use		internal	internal	internal	internal
Lifting time	s	47	47	70	70
Lowering time	s	47	47	70	70
Battery	V / A	4X6	4X6	4X6	4x6
Battery capacity	V/Ah(C5)	24/200	24/ 200	24/280	24/280
Battery charger	V/A	24/25	24/25	24/25	24/25
Oil tank capacity	l	30	30	30	30
Drive speed (safety/fast)	km/h	0,60/3	0,60/3	0,60/3	0,60/3
Inclination long. /trav.	°	3°/2°	3°/2°	3°/1,2°	3°/1°
Gradeability	%	26	20	23	23
Inside / Outside turning radius	m	0/2,28	0/2,28	0/2,28	0/2,28
Steering	°	90	90	90	90
Tyre dimensions and type	mm	Ø 410 x 150	Ø 410 x 150	Ø 410 x 150	Ø 410 x 150
CUSHION Non-marking white tyres					
Total weight	kg	2000	2750	3430	3600



### Standard Version

- Electro-hydraulic transmission and proportional controls
- Deep Cycle batteries and integrated sealed charger
- Electric scissor protection
- Manual roll-out extension deck (m 1,50)
- Horn, inclinometer, voltmeter, hourmeter
- Tilt sensor with automatic stop
- Battery level indicator on platform and ground controls with flat battery lift cut-out
- 90 ° Steering
- All-motion alarm
- Automatic pot-hole system for translation at max. height
- Pin based load limiter on platform
- 230 V electric line predisposition on the platform
- Foldable handrails
- Lateral forklift pockets
- Anchorage and lifting points
- Telematic connector
- CE Declaration of conformity **CE**

### Options and accessories

- Flashing warning lights (n.2)
- Control box protection cap
- 230V power line on platform
- 230V power line on platform with circuit breaker
- Deep Cycle battery 24V, 280Ah (standard in X12 and X14)
- Kit for centralized battery topping
- Air / Water line to platform with quick coupling
- Gel batteries (AGM)
- Ground level controls display and built-in diagnostics
- SAFE Secondary protection system
- Fleet management Kit